



Die Luftreiniger



AirTracker

OPTIMUM AIR - MONITORING, CONTROLLING, SAVING

Benefits:

- ✓ **Monitoring and documentation** of air quality and dust concentration
- ✓ Smart filter system control - **the key to lower energy costs**
- ✓ Including **update service** (Over the Air, OTA)
- ✓ **Humidity measurement for perfect welds**

www.teka.eu/AirTracker

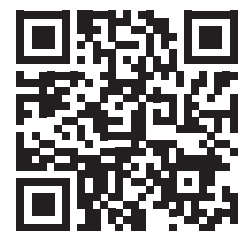

THE CLEANEST PLACE IN THE WORLD: **YOUR WORKPLACE**



Flexible and connected

Thanks to WLAN, Ethernet port and a 4G connection



User friendly

Thanks to quick configuration via a display directly on the device



LED light area

for visual display of the air quality on the AirTracker



Energy cost savings

through needs-based filter system control

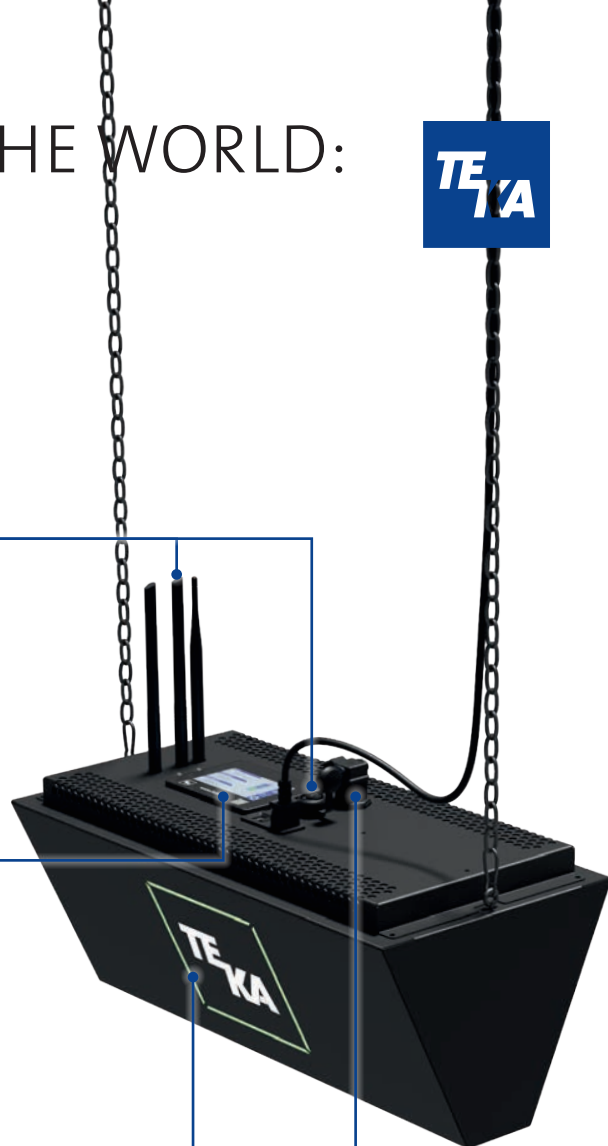



TECHNICALLY CONVINCING EVERYTHING AT A GLANCE



TECHNICAL DATA

Frequency standard	WLAN connection 802.11b/g/n compliant wireless standard	Display	HMI - Touch Display 4,3"
Security	128-bit AES encryption	Display size	480 x 272 px
Connections	Ethernet / Wifi / 4G	Voltage	230 V / 110 V
Interfaces	3 potential-free contacts for external devices (e.g. filter system)	Temperature	-10°C to + 50°C
Data transfer	Data logger	Air humidity	0% to 90%
Remote access	via mobile device	Dust	0,0 to 6,0 mg/m ³
		Weight	approx. 12 kg
		Dimensions (W x D x H)	574 x 285 x 446 mm
		Case	Metal powder-coated
		Colour	RAL 7016

ACCESSORIES

Art. No.	Execution
2017014032	Wall / ceiling bracket for AirTracker
2017014033	AirTracker connection cable 7x0.75mm ² , approx. 50 m

TECHNICALLY CONVINCING EVERYTHING AT A GLANCE

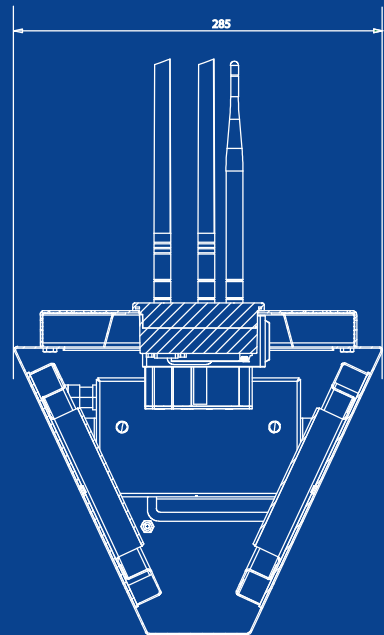
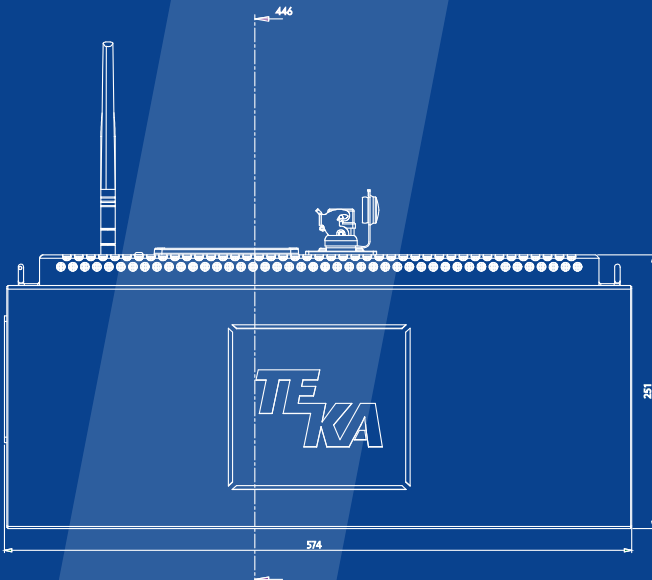
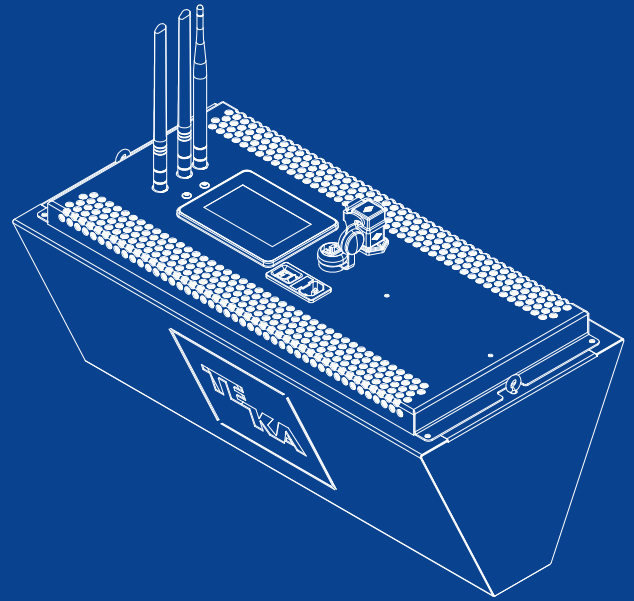
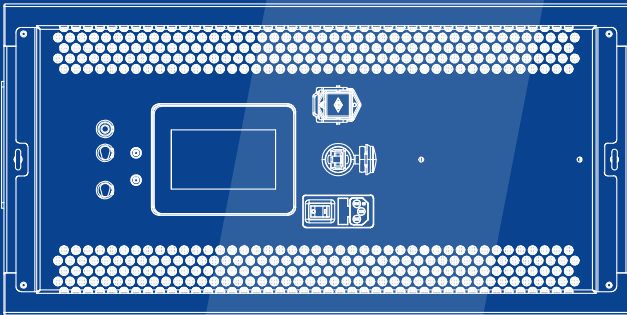

100 % SERVICE, 100 % SAFETY

THE 360° SERVICE CONTRACT



Your benefits:



Save money in the future

Service conditions are more cost-effective than maintenance on request



Get the maximum out of your service

Benefit from the 360° service offer all year round



Maximum operational reliability

Reduction of unnecessary downtime



We make the appointments

No more worries about upcoming maintenance appointments



First-class support

Prioritised scheduling when time is of the essence

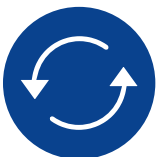

Warranty extension

We extend the warranty period to 36 months

Do you still have questions or would you like to enjoy the benefits of the 360° service package?

Get in touch with us!

Phone +49 2541 84 84 1-428

info@teka.eu

www.teka.eu/service-date



OUR PRINCIPLES FOR AN EXTRACTION SYSTEM

**Solution oriented:**

We don't see the problem, we find the solution.

**Customer focus:**

Together we develop suitable solutions, customised specifically for you.

**Reliable products:**

Performance and functionality take centre stage.

**Sustainability:**

Environmentally friendly production is important to us.

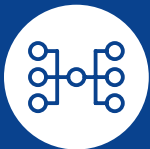
**Qualified advice on site:**

Our dealer network offers competent support.

**Strong partners:**

Benefit from the expertise of our partners in various areas.

**Complete service:**

We accompany you from consultation to maintenance.

**Almost 30 years of experience:**

We are the world market leader in filter and extraction technology.

**Versatile in use:**

Our products are suitable for all applications and industries.

**Legal compliance:**

We help you to comply with legal requirements.

**Employee health:**

Our solutions reduce the risk of dangerous long-term illnesses.

**Employer attractiveness:**

Clean workplaces are a basic requirement for basic equipment for skilled workers.

**Employee motivation:**

Healthy employees are more motivated.

**Cost reduction:**

Clean environments protect machines and reduce maintenance costs

MAKE YOUR WORKPLACE **THE CLEANEST PLACE IN THE WORLD**

For almost 30 years, we have been ensuring healthy air wherever smoke and dust arise in the workplace. Whether in industry, laboratories or offices - there is always a solution for clean air. We develop a suitable concept together with our customers, because we are the special machine builders, the occupational safety professionals or simply #dieLuftreiniger.

TEKA Absaug- und Entsorgungstechnologie GmbH

Millenkamp 9 · 48653 Coesfeld · Germany

Tel. +49 2541 84 84 1-0

info@teka.eu

www.teka.eu



[@teka.die.luftreiniger](https://www.instagram.com/teka.die.luftreiniger)

